

**A
REVOLUTION**
in the
Decoration of
"Deep" Reusable
Containers



US25-E FRAME

Hot Stamp Decorating Machine

Previously the decoration of "deep" containers that need more than 10" throat depth required users to select a more costly 12-ton hot stamp system despite the fact that the extra tonnage was excessive for their artwork needs. The new US25-E Frame revolutionizes the ability to decorate "deep" reusable containers such as crates, bins, totes, roll-off carts, garbage cans and industrial containers with a cost-effective 2.5-ton system.

PRODUCT DETAILS

60%

Greater Throat Depth

The 16" throat depth represents a 60% increase in printing depth previously attainable with an affordable 2.5-ton system



Significant Cost Savings

The new ability to realize 16" throat depth with a 2.5-ton system can generate cost savings of up to 40% or roughly \$20,000 per system

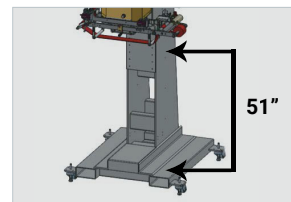

Additional Part Clearance

Whereas traditional frames provide up to 16" part clearance, the E-Frame allows for up to 51" clearance making it an optimal choice for larger containers

Trusted Partner for Your Product Decorating Needs

United Silicone 4471 Walden Avenue, Lancaster, NY 14086
Tel +1 (716) 681 8222 Fax +1 (716) 681 8789
Email info@unitedsilicone.com

www.unitedsilicone.com www.itwids.com

A MEMBER OF

IDS | A Division of ITW



US25-E FRAME

- Reduced setup time
- High reliability, efficiency and simplified trouble-shooting
- Stable, consistent head travel and smooth foil advance for optimal quality and repeatability
- Accurate cycling for minimal transfer/foil waste
- Safe, quiet, smooth cycling
- Suited for hot stamp or heat transfer applications

A	B	C	D	E	F
88	47	58	16	21	41

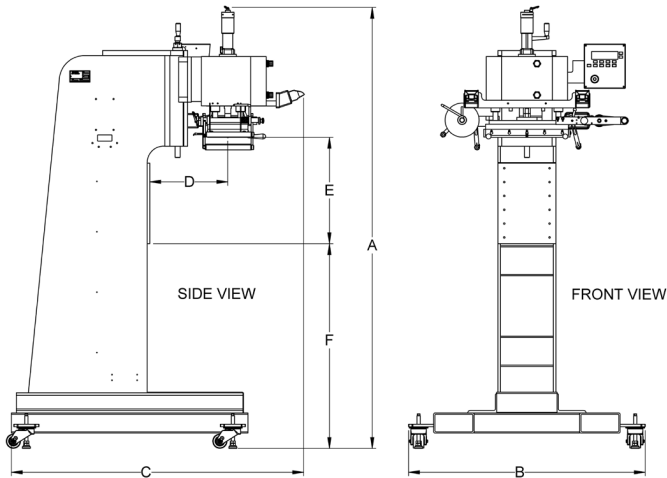

SUPERIOR SUPPORT - SUPERIOR DECORATION

Superior repeatability is ensured by United Silicone's best-in-class service support. The ability to calculate precisely how potential minute part variation will impact image quality, makes it possible for United Silicone's experts to create optimized brand plates (dies) capable of producing a crisp, quality decoration time and time again.

TECHNICAL DATA

Maximum Stamping Force (Tons) 2.5

Head Stroke 0" - 3"

Head Size (standard) 8" x 16"

A - Height 88"

B - Width (Wide) 47"

C - Depth (Deep) 58"

D - Throat Depth 16"

E - Working Height 21"

F - Clearance 41"

Electrical Requirements (Volts) 220

Air Requirements (CFM) 5

Air Requirements (PSI) 50-100

Working Pressure (PSI) 50-100

Net Weight (Pounds) 1600



Trusted Partner for Your Product Decorating Needs

United Silicone 4471 Walden Avenue, Lancaster, NY 14086

Tel +1 (716) 681 8222 Fax +1 (716) 681 8789

Email info@unitedsilicone.com

www.unitedsilicone.com www.itwids.com

A MEMBER OF

IDS | A Division of ITW