

# USR3EX

## Hot Stamping and Heat Transfer Machine

The United Silicone Model R3EX Hot Stamping Machine applies foils or pre-printed heat transfers to extrusions at a rate of up to 70 feet per minute. Various extrusion shapes are accommodated by the silicone rubber roller that operates effectively on flat, contoured, and complex extrusion profiles. Multiple units can be configured for increased flexibility, allowing coverage of large areas and a wide variety of part dimensions.

**Excellent for application of hot stamp foil and heat transfer decals to extruded products**

### Stamping Applications:

- Extruded products
- Vertical blinds (metal & plastic)
- Decorative moldings
- Picture frames

### Features:

- Swiveling range 0-360°
- Guide rollers for special profiles
- PLC-based control system
- Adjustable speed up to 70ft./ min.
- Dual foil payout for quick changeover
- Machine can accommodate silicone rubber rollers up to 6 inches in diameter and from 1 to 3 inches long.

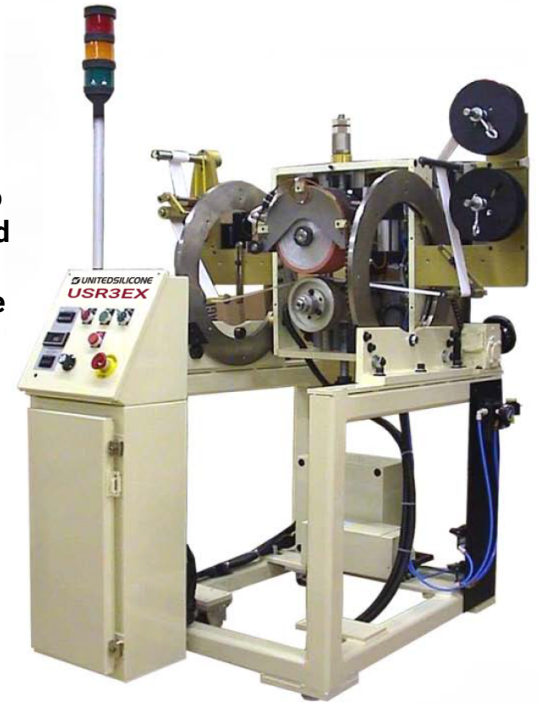

### Model US R3EX

- Shown with optional dual foil payout

**As your one source for decorating equipment, tooling and accessories, United Silicone can deliver turnkey hot stamping and heat transfer systems that are designed for your specifications. We also offer the industry's most complete line of tooling and supplies, designed to optimize the performance of your decorating equipment.**

### Trusted Partner for Your Product Decorating Needs

United Silicone 4471 Walden Avenue, Lancaster, NY 14086  
Tel +1 (716) 681 8222 Fax +1 (716) 681 8789  
Email [info@unitedsilicone.com](mailto:info@unitedsilicone.com)

[www.unitedsilicone.com](http://www.unitedsilicone.com) [www.itwids.com](http://www.itwids.com)

A MEMBER OF

 **IDS** | A Division of ITW

**CONSTRUCTION FEATURES**

- Rugged steel machine frame
- Machine base with leveling feet offers a sturdy base and independent leveling adjustment at all four corners.

**ACCESSORIES AND OPTIONS**

- Dual foil payout
- 3" Foil Core Adapter
- Non Rotating Head
- Vacuum waste foil pickup



**SPECIFICATIONS**

Roller Diameter (Inches):	up to 8	Electrical Requirement (Volts):	220 1 phase
Roller Width (Inches):	up to 4	Air Requirement (CFM):	3
Working Height Under Roller (Inches):	3.5	Air Requirement (PSI):	100
Approximate Dimensions (Inches):	57 High 45 Wide 49 Deep		

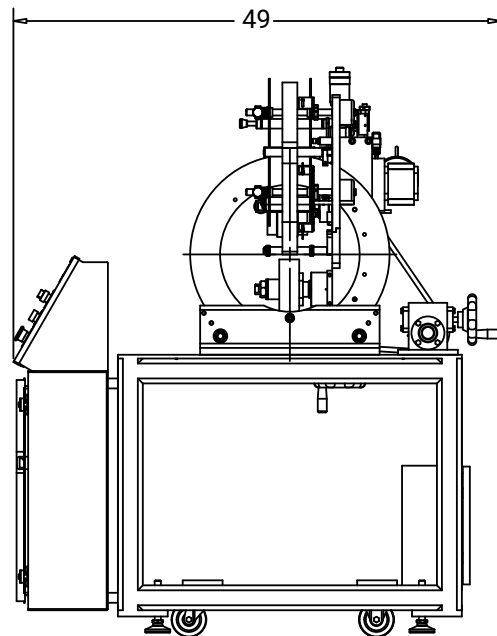
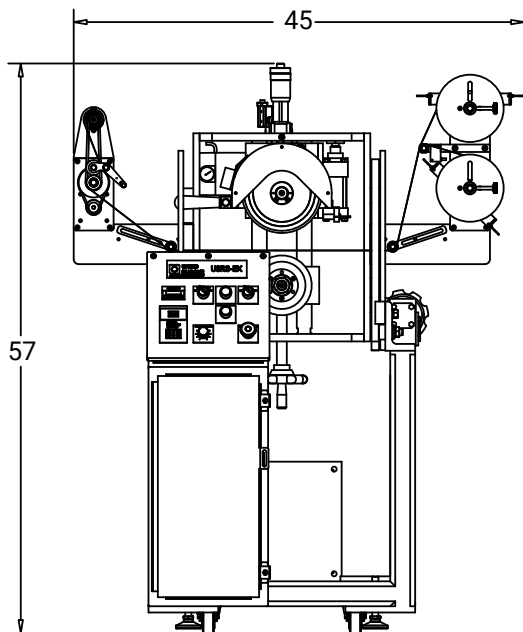

**Trusted Partner for Your Product Decorating Needs**

United Silicone 4471 Walden Avenue, Lancaster, NY 14086  
 Tel +1 (716) 681 8222 Fax +1 (716) 681 8789  
 Email info@unitedsilicone.com

[www.unitedsilicone.com](http://www.unitedsilicone.com) [www.itwids.com](http://www.itwids.com)

A MEMBER OF

